

MODÈLE #
WMB2



SUPPORT **MURAL**



Le support mural **WMB2** est un support de montage robuste conçu pour fournir une plateforme sûre et stable pour une gamme de caissons de caméras, y compris les modèles EB2, TEB, XEB et D2. Conçu pour être durable et flexible, le WMB2 garantit un montage et un support fiables, ce qui en fait un accessoire essentiel pour les installations de surveillance intérieures et extérieures.

DIMENSIONS

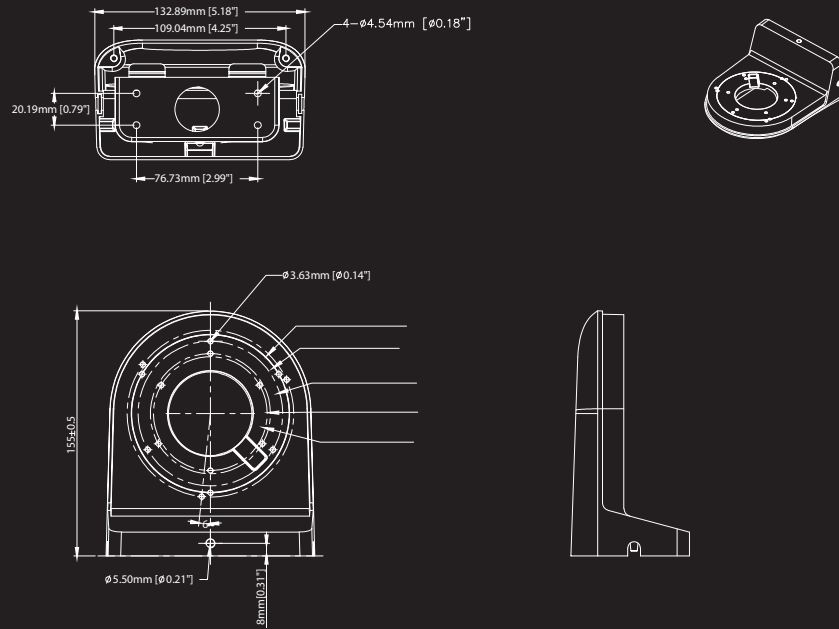

CAMÉRAS COMPATIBLES



TEBFDAIP8MP28-AI
CAMÉRA SÉRIES T



XEBATVI8MP28-AI-64G
CAMÉRA SÉRIES X



XSEBATVIP4MP28-AI
CAMÉRA SÉRIES X



D2FDA28IP5MP-AI
CAMÉRA SÉRIES D

TÉLÉCHARGER L'APP SMART GUARDIAN

