

MODEL #
PTZ20XTVI



FENNEC SERIES



HD ANALOG **PTZ CAMERA**



5MP
RESOLUTION



2MP
Resolution

4.7-94MM Lens



IR Up to 120M

**20X Optical
Zoom**

Introducing the **PTZ20XTVI** Security Camera - your ultimate surveillance solution for unparalleled monitoring capabilities. This analog camera boasts a powerful 20X optical zoom paired with a crisp 2MP resolution, ensuring every detail is captured with clarity. With its 4.7-94mm motorized lens, you have the flexibility to adjust focus effortlessly. Equipped with an IP66 protection rating, this camera is built to withstand harsh weather conditions, making it ideal for both indoor and outdoor use. Enhance your security setup with the PTZ20XTVI and enjoy peace of mind knowing your property is under vigilant watch.



IP66
Dustproof
& Water-Resistant

TVI-CVI-AHD-960H
RS-485
Communication



CAMERA

Image Sensor	1/2.8" SONY CMOS (IMX307)
Horizontal Resolution	2MP
S/N Ratio	>50db

PTZ

Horizontal Rotation Speed	280°/s
Horizontal Rotation Range	0°~360°
Tilt Rotation Speed	120°/s
Tilt Rotation Range	0°~90°
Audio Flip	Support
Ratio Speed	Support
360° Scan	Support
A-B Scan	Support
Preset Points	220
Guard Tours	4 groups
Guard Points	Max.16 points

LENS

Focus Length	4.7mm-94mm
Focus Control	20X Optical Zoom

NIGHT VISION

Infrared LED	6PCS Array 42Mil IR LED
IR Range	120m
Auto Control IR LED	PWM

COMMUNICATION

Communication Protocol	UTC
Communication Interface	COAXIAL CABLE
Audio	N/A
Alarm	N/A

GENERAL

Operating Temperature	Indoor: 0°~ +40° Outdoor: -40°~ +60°
Operating Humidity	≤90% Non Condensing
Ingress Protection	IP66
Heater & Blower	Auto temperature control
Power	DC12V/3A
Lightning Protection	Transient voltage 6000V
Dimension	208mm*136mm*251mm
Weight	3Kgs

DIMENSIONS

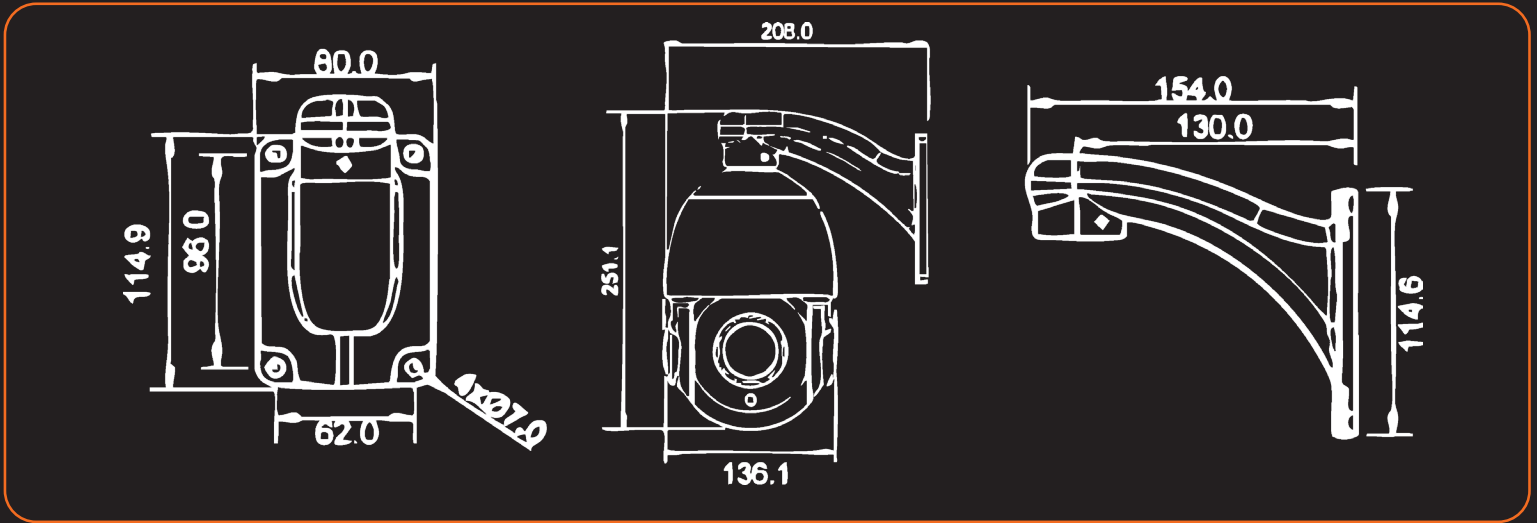

COMPATIBLE ACCESSORIES

CEILING MOUNT SOLUTION



 **CMB6-P**
CEILING MOUNT

CORNER MOUNT SOLUTION

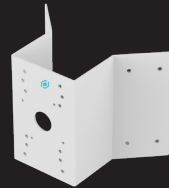

 **COMB6**
CORNER MOUNT BRACKET

POLE MOUNT SOLUTION



 **PMB6**
POLE MOUNT BRACKET

WALL MOUNT SOLUTION

Included

DOWNLOAD THE SMART GUARDIAN APP

